



Metallic Hard Sealing Butterfly Valve



Metal Seal Butterfly Valve

■ Disc and shaft

Rigid sturdy design, integrated stem taper pin reliably connected with the disc, the stem is completely covered in the valve plate, protecting stem from media erosion. The good disc fluid dynamics section design, not only improves the flow capacity of the valve, but also reduces the pressure drop.

■ Body

Integrated cast structure, has good rigidity and no leakage characteristics. Valve seat and body are-in-one design, seat adopts oblique cone structure, forming a complete seal surface, greatly enhance the reliability of the seal.

■ **Disc position indicator**
Reliable disc location signage

■ **Yoke**
the overall rectangular bracket, better rigidity, more assembly space

■ **Stem**
the external strength of stem is lower than that of internal strength, which ensures stem internal connection safe and reliable

■ **Stem anti-fly**
Prevent valve stem from spray wounding under internal pressure

■ **Disc pin**
Close bonding of the plane area, reduce the local contact stresses between the pin and the stem, and to improve the reliability of the connection of the disc and stem.

■ **Stopper pin**
Make sure rigid connection between yoke and valve body, reliable for transferring torque

■ **Hard facing seat**
Integrated hard facing valve seat, can bead weld different materials, to meet the requirements of a variety of conditions, and to ensure the long-term sealing performance under harsh conditions.

■ **Anti-dust ring**
To prevent granular media into the valve sleeve affecting operation

■ **Bottom seal**
Multiple-seal, ensure that the valve itself connection part no leakage.

■ **Self-lubricating bushings**
Reduce the rotational torque, supporting stem and its effective separation with the valve body, reducing the wear of the valve stem.

■ **Axial positioning**
Axial reliable positioning, avoid the valves' trim playing along with the axial in the process of valve turn on and off.

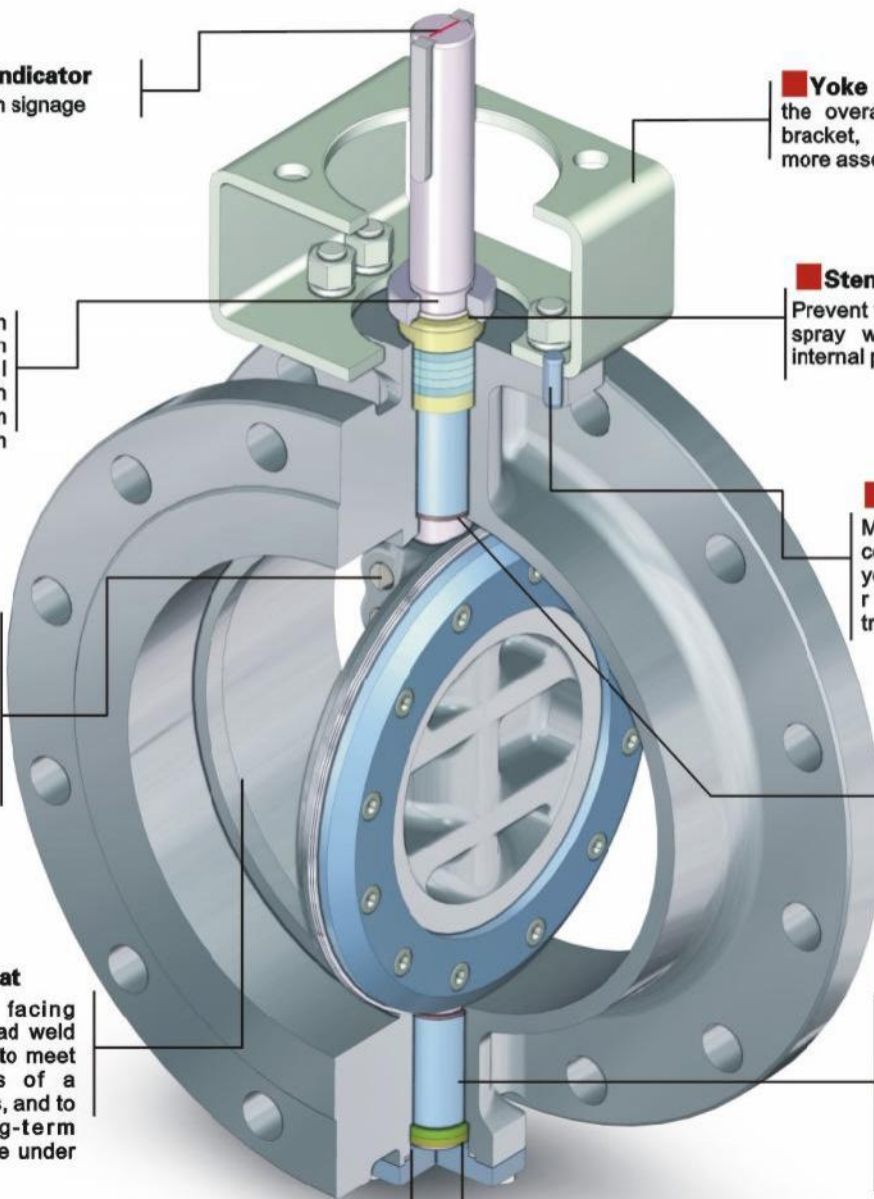

Metal Seal Butterfly Valve

■ Main Material

Body: ASTM A216 WCB

A351 CF8、CF8M、CF3、CF3M

Stem: ASTM A182 F6a、XM19

A564 630(17-4PH)

Disc: ASTM A216 WCB

A351 CF8、CF8M、CF3、CF3M

Yoke: ASTM A576 1025

Bottom cover: ASTM A105

A240 304、304L、316、316L、

Seal ring: ASTM A240 304+FG、316+FG

A564 630(17-4PH)

Radial bearing: ASTM A276 304、316

Disc pin: ASTM A182 F6a、XM19

A564 630(17-4PH)

Screw/ Stud: ASTM A193 B7、B7M、B8、B8M

Nut: ASTM A194 2H、2HM、8、8M

■ Scope of supply

Size: NPS3~NPS60 DN80~DN3000

Class: CL150~CL1500 PN6~PN160

Temperature: -196°C~600°C



■ Valve Operation

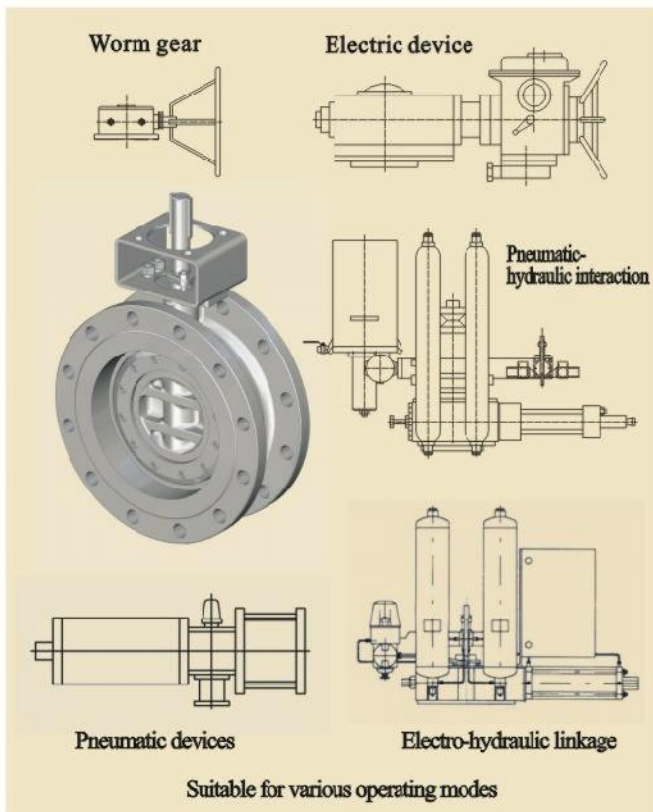

Metal Seal Butterfly Valve

Three eccentric structural features

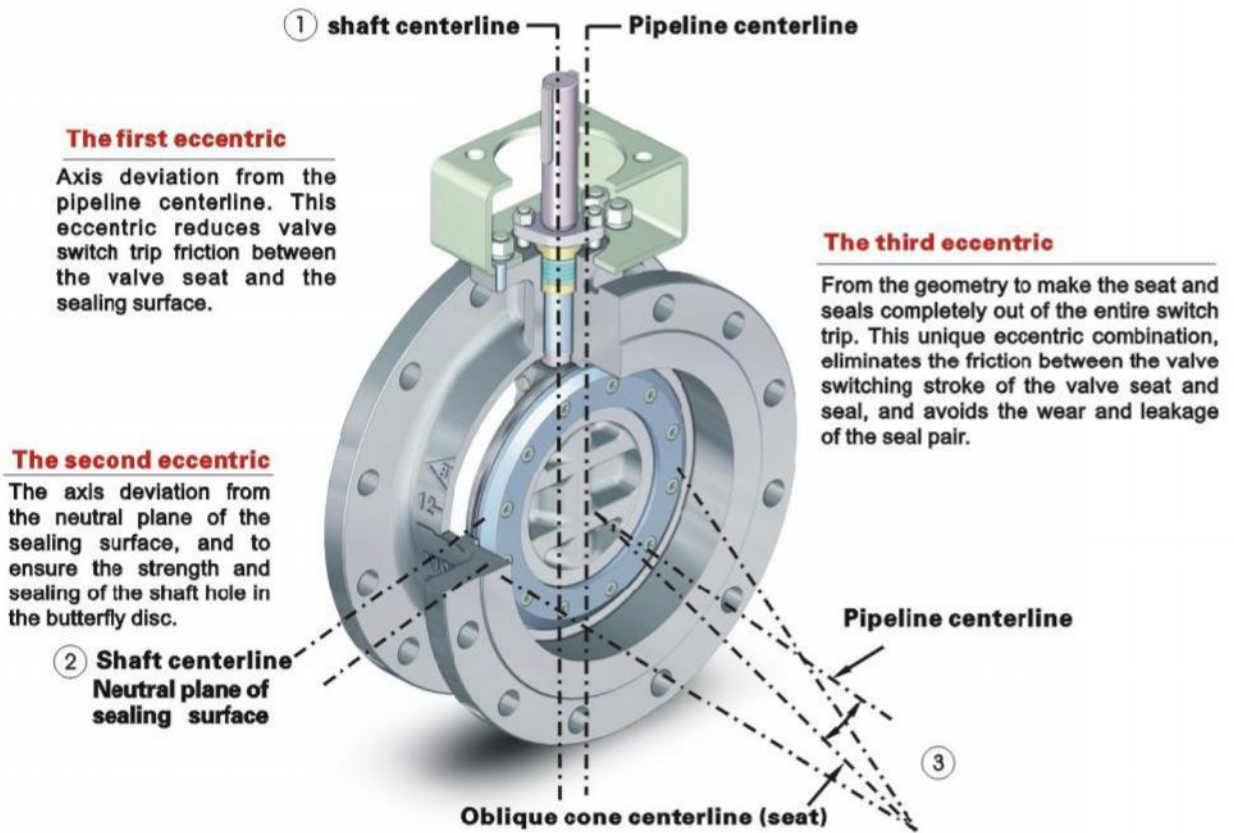

Elastic metal seals

The BTL DM00 series butterfly usually relies on the stainless steel - graphite composite seals assembled in the butterfly disc to achieve zero leakage. In the process of turning off valve sealing, the sealing ring external taper by the extrusion of the inner cone in the seat, producing mainly circumferentially distributed radial elastic deformation, forming an elastic force, resulting in specific pressure in the sealing surface, and completely cut off the medium. (As right picture shown) Due to the outer conical surface of the steel layers and the seat tapered inner surface can form a good sealing effect, even if the single steel sealing surface of the seal ring failed sealing, which does not affect the overall sealing performance. Under special working conditions, it also will adopt monolithic all-metal seals to meet the needs of the special working conditions. (As the following picture shown)

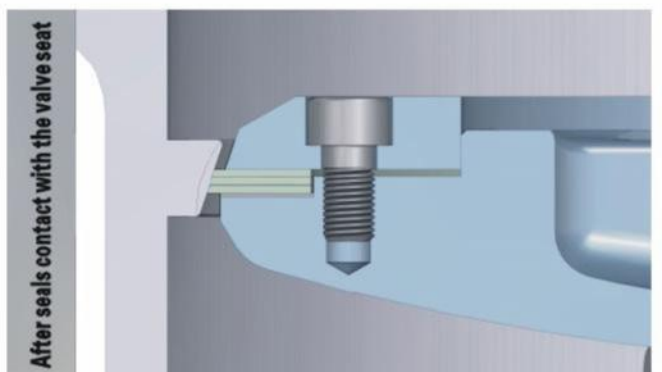
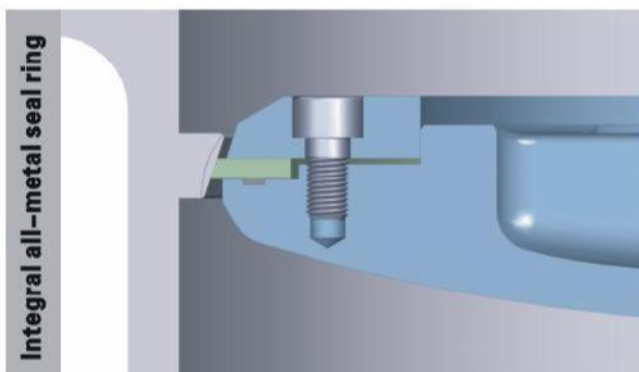
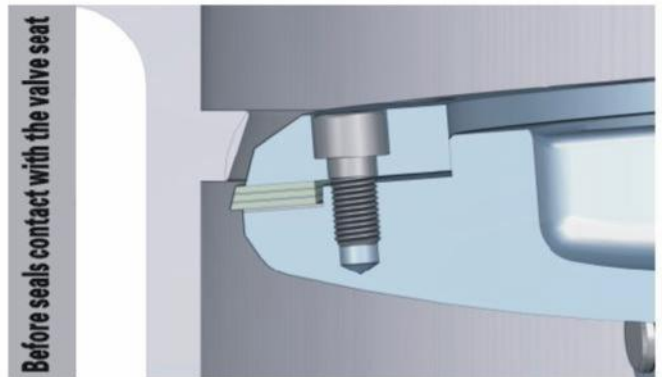

Metal Seal Butterfly Valve

Class 150/300/600/900/1500 Dimensions

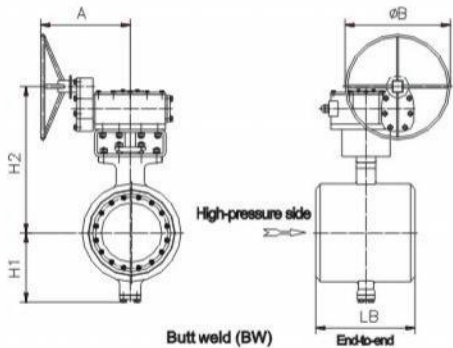
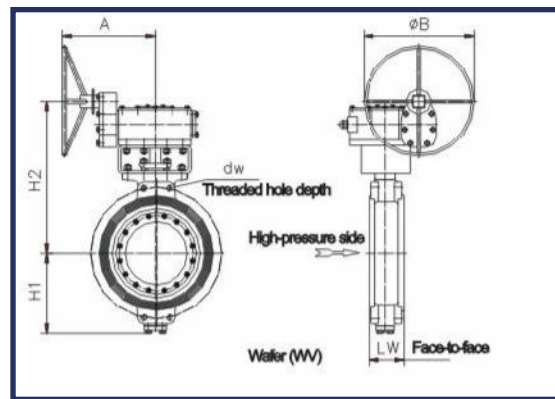
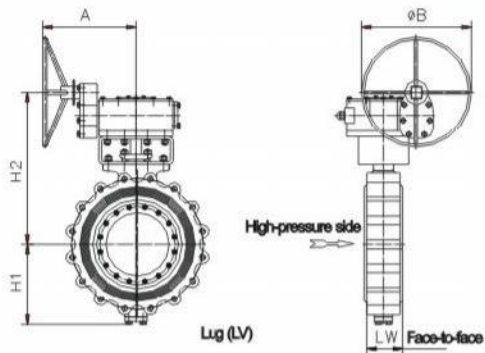
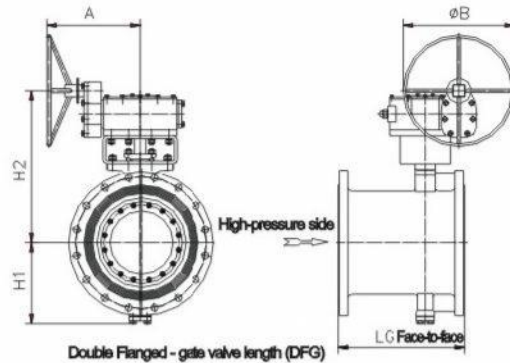
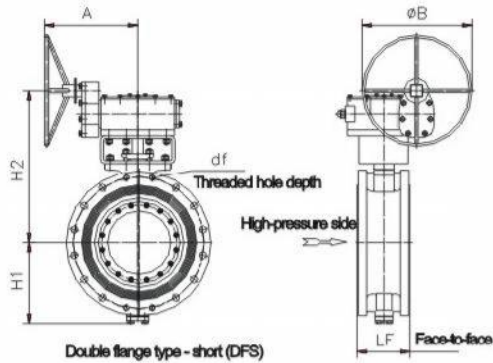

Manufacturing standards

Design: API 609, ASME B16.34
 Face to face: API 609, ASME B16.10
 Flange connection dimension: ASME B16.5 (NPS = 24) / B16.47 (A Series)
 Welding end dimensions: ASME B16.25
 Inspection: API 598
 Fire resistance test: API 607
 If there are other standards or requirements for manufacturing valves,
 Please contact with us

NPS	Class 150										Weight(kg)				
	LF	LG	LW	LB	H1	H2	A	B	df	dw	DFS	DFG	LV	WV	BW
3	114	203	48	180	110	195	162	200	-	-	18	22	12	10	15
4	127	229	54	190	130	215	162	200	-	-	23	30	18	12	20
6	140	267	57	210	155	245	162	200	-	-	32	40	24	15	25
8	152	292	64	230	190	325	230	350	-	-	48	71	45	30	49
10	165	330	71	250	225	380	360	600	-	-	88	108	68	47	71
12	178	356	81	270	265	420	402	600	-	-	128	157	100	79	104
14	190	381	92	290	290	445	402	600	-	-	158	195	121	84	144
16	216	406	102	310	325	515	520	600	-	-	223	272	175	140	180
18	222	432	114	330	355	550	543	750	-	30	286	344	227	187	232
20	229	457	127	350	400	590	543	750	-	30	338	412	262	227	272
24	267	508	154	390	455	695	604	750	-	35	511	625	395	355	415
28	292	610	165	430	520	815	642	750	35	35	837	1025	585	525	605
30	318	610	190	450	555	850	642	750	35	35	983	1205	665	585	705
32	318	660	190	470	580	875	660	750	40	40	1163	1450	780	700	720
36	330	711	203	510	650	990	855	800	40	40	1566	1930	1050	1080	930
40	410	762	216	550	710	1050	855	800	40	40	2130	2900	1570	1320	1670
48	470	864	254	630	820	1200	950	915	40	40	3260	3900	2300	2050	2600
56	530	965	279	710	970	1765	1056	950	45	45	4700	5800	3300	3100	3800
60	560	1016	318	750	1020	1815	1056	950	45	45	5250	6460	3600	3480	4230

Metal Seal Butterfly Valve

Class 300											Weight(kg)				
NPS	LF	LG	LW	LB	H1	H2	A	B	df	dw	DFS	DFG	LV	WV	BW
3	114	282	48	180	120	210	162	200	25	-	20	25	16	14	17
4	127	305	54	190	145	245	162	200	25	-	30	38	23	20	25
6	140	403	59	210	180	320	230	350	25	-	58	71	45	42	50
8	152	419	73	230	210	370	402	600	30	-	82	98	66	60	71
10	165	457	83	250	245	445	520	600	30	20	146	170	120	110	130
12	178	502	92	270	290	780	520	600	35	20	186	224	148	136	160
14	190	762	117	290	325	525	543	750	35	25	262	312	212	194	228
16	216	838	133	310	365	585	604	750	40	30	350	412	286	264	308
18	222	914	149	330	395	640	604	750	40	30	412	496	328	280	358
20	229	991	159	350	425	735	642	750	40	30	555	660	450	415	485
24	267	1143	181	390	505	305	660	750	45	40	760	920	598	544	652
28	292	1346	229	430	580	920	855	800	50	40	1185	1985	925	845	1015
30	318	1397	241	450	620	950	855	800	55	45	1490	1796	1184	1082	1286
32	318	1524	241	470	650	1000	855	800	55	45	1670	2030	1310	1190	1430
36	330	1727	241	510	710	1080	130	915	60	50	2340	2800	1878	1724	2030
40	410	1930	300	550	730	1505	1056	950	50	45	3240	3850	2628	2424	2832
48	470	2134	350	630	830	1625	1056	950	55	50	4085	4930	3210	2922	3496

Class 600											Weight(kg)				
NPS	LF	LG	LW	LB	H1	H2	A	B	df	dw	DFS	DFG	LV	WV	BW
4	190	432	64	190	170	285	220	350	25	20	45	56	34	30	36
6	210	559	78	210	230	365	402	600	30	25	104	128	81	74	89
8	230	660	102	230	255	440	520	600	35	25	184	221	147	134	159
10	250	787	117	250	315	490	543	750	35	30	300	362	238	217	258
12	270	838	140	270	345	580	604	750	35	30	395	478	320	293	346
14	290	889	155	290	380	605	604	750	40	30	457	554	360	328	393
16	310	991	178	310	420	685	642	750	45	35	655	790	520	475	565
18	330	1092	200	330	470	735	660	750	50	40	797	970	624	566	682
20	350	1194	216	350	510	825	754	800	50	40	1114	1337	891	816	965
24	390	1397	232	390	565	880	855	800	55	45	1601	1940	1262	1148	1375
28	430	1549	270	430	630	1000	900	915	60	45	2420	2906	1934	1772	2096
30	450	1651	290	450	660	1470	1056	950	60	45	3040	3592	2488	2304	2672
32	470	1778	310	470	695	1510	1056	950	70	50	3314	3948	2688	2468	2896
36	510	2083	350	510	755	1570	1056	950	75	50	3900	4700	3090	2820	3360

Class 900											Weight(kg)				
NPS	LF	LW	LB	H1	H2	A	B	df	dw	DFS	LV	WV	BW		
8	250	170	250	295	475	543	750	50	40	252	204	188	220		
10	270	190	270	335	510	543	750	50	40	327	257	233	280		
12	290	210	290	370	600	604	750	50	40	470	370	336	403		
14	310	230	310	405	675	642	750	55	45	603	483	444	523		
16	330	250	330	435	710	642	750	60	50	705	555	515	595		
18	350	270	350	480	805	754	800	70	55	1080	867	796	938		
20	370	290	370	515	825	855	800	75	60	1365	1097	1008	1186		
24	470	330	470	600	970	900	915	90	80	2463	1950	1778	2120		

Class 1500											Weight(kg)				
NPS	LF	LW	LB	H1	H2	A	B	df	dw	DFS	LV	WV	BW		
8	310	210	310	350	490	543	750	60	55	297	236	194	256		
10	370	210	370	400	600	604	750	70	60	484	379	310	415		
12	410	270	410	450	700	642	750	75	65	738	578	472	631		
14	450	290	450	480	730	660	750	85	70	930	717	575	788		
16	490	330	490	540	820	855	800	95	85	1475	1135	905	1247		
18	530	350	530	580	870	855	800	100	90	1752	1367	1110	1496		
20	570	370	570	610	950	900	915	110	100	2380	1890	1565	2054		
24	650	410	650	700	1500	1056	950	130	110	3447	2773	2323	3000		

Metal Seal Butterfly Valve

PN6/10/16/25/40/63/100/160 Dimensions

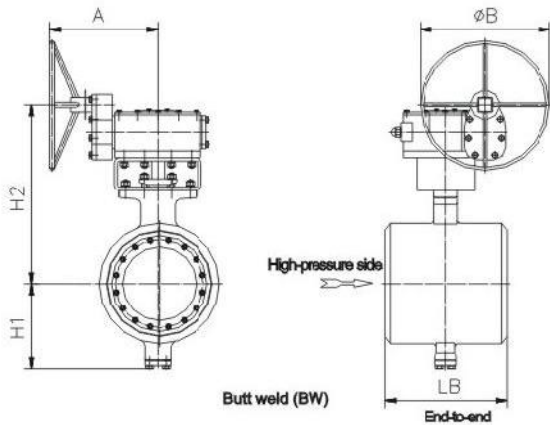
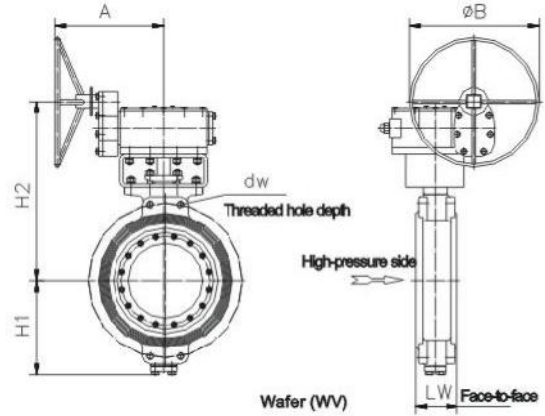
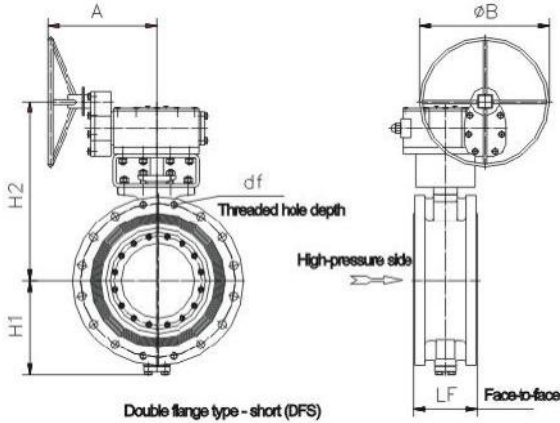

Manufacturing standards

Design: API 609, ASME B16.34
 Face to face: BS EN 558/ISO 5752
 Flange Size: BS EN 1092-1
 Welding end dimensions: ASME B16.25
 Inspection: API 598
 Fire resistance test: API 607

If there are other standards or requirements for manufacturing valves, Please contact with us

DN	PN6/10								(kg)			
	LF	LW	LB	H1	H2	A	B	dw	DFS/PN16	DFS/PN10	wv	BW
80	114	46	180	110	195	162	200	-	16	18	13	15
100	127	52	190	130	215	162	200	-	18	20	14	17
150	140	56	210	155	245	162	200	-	26	30	20	25
200	152	60	230	190	280	162	350	-	34	40	26	33
250	165	68	250	225	360	230	350	-	60	66	47	56
300	178	78	270	260	385	230	600	-	68	80	55	67
350	190	78	290	290	435	360	600	-	95	105	71	88
400	216	102	310	320	470	402	600	-	122	138	97	117
450	222	114	330	340	530	520	600	-	174	193	140	166
500	229	127	350	385	560	520	600	-	196	218	155	186
600	267	154	390	440	635	543	750	-	280	322	230	276
700	292	165	430	510	740	604	750	25	420	485	344	415
800	318	190	470	570	800	604	750	30	498	585	395	486
900	330	203	510	620	910	642	750	30	630	741	527	635
1000	410	216	550	675	1000	660	750	30	830	975	673	824
1200	470	254	630	800	1130	754	800	35	1410	1655	1127	1391
1400	530	279	650	910	1240	855	800	35	2160	2540	1712	2126
1600	600	318	680	1030	1435	901	915	40	2850	3350	2310	2830
1800	670	356	720	1130	1535	901	915	40	3520	4400	2960	3680
2000	760	406	760	1230	1635	901	915	40	4638	5797	3558	4478
2200	800	450	800	1355	2160	1565	950	45	5220	6526	4400	5460
2400	850	500	850	1460	2265	1565	950	45	6450	8063	5320	6690
2600	900	550	900	1560	2365	1565	950	45	7274	9093	5936	7515
2800	950	600	950	1670	2475	1565	950	45	8545	10680	6888	8784
3000	1000	650	1000	1780	2600	1565	950	50	11020	13770	8142	9996

Metal Seal Butterfly Valve

PN16/25										(kg)			
DN	LF	LW	LB	H1	H2	A	B	Df	dw	DFS/PN16	DFS/PN25	WV	BW
80	114	46	180	110	195	162	200	-	-	18	20	10	15
100	127	52	190	130	215	162	200	-	-	23	25	12	20
150	140	56	210	155	245	162	200	-	-	30	36	15	25
200	152	60	230	190	325	230	350	-	-	42	55	30	49
250	165	68	250	225	380	360	600	-	-	80	104	47	71
300	178	78	270	265	420	402	600	-	-	115	158	79	104
350	190	78	290	290	445	402	600	-	-	142	174	84	144
400	216	102	310	325	515	520	600	-	-	200	245	140	180
450	222	114	330	355	550	543	750	-	30	257	315	187	232
500	229	127	350	400	590	543	750	-	30	304	375	227	272
600	267	154	390	455	695	604	750	-	35	460	560	355	415
700	292	165	430	520	815	642	750	35	35	753	920	525	605
800	318	190	470	580	875	660	750	40	40	1045	1280	700	720
900	330	203	510	650	950	855	800	40	40	1410	1723	1080	930
1000	410	216	550	710	1010	855	800	40	40	1920	2345	1320	1670
1200	470	254	630	820	1090	950	915	40	40	2935	3586	2050	2600
1400	530	279	650	935	1180	1056	950	45	45	4220	5170	3100	3800
1600	600	318	680	1060	1275	1056	950	45	45	5450	6560	3680	4830
1800	670	356	720	1160	1375	1056	950	45	45	6750	8252	4580	6510
2000	760	406	760	1265	1485	1056	950	50	50	8820	10780	5860	7840

PN40/63										(kg)			
DN	LF	LW	LB	H1	H2	A	B	Df	dw	DFS/PN40	DFS/PN63	WV	BW
80	114	46	180	120	210	162	200	20	20	17	23	14	17
100	127	52	190	145	245	162	200	20	20	25	35	20	25
150	140	56	210	180	320	230	350	25	25	51	65	42	50
200	152	60	230	210	370	402	600	25	25	68	88	60	71
250	165	68	250	245	445	520	600	30	30	124	156	110	130
300	178	78	270	290	780	520	600	30	30	156	205	136	160
350	190	78	290	325	525	543	750	35	35	218	302	194	228
400	216	102	310	365	585	604	750	35	35	308	396	264	308
450	222	114	330	395	640	604	750	35	35	332	462	280	358
500	229	127	350	425	735	642	750	40	40	485	625	415	485
600	267	154	390	505	305	660	750	40	40	652	868	544	652

PN 100										(kg)		
DN	LF	LW	LB	H1	H2	A	B	Df	dw	DFS	WV	BW
80	180	64	180	150	225	220	350	25	20	35	22	28
100	190	64	190	170	285	220	350	25	20	45	30	36
150	210	76	210	230	365	402	600	30	25	104	74	89
200	230	89	230	255	440	520	600	30	25	184	134	159
250	250	114	250	315	490	543	750	35	30	300	217	258
300	270	114	270	345	580	604	750	35	30	395	293	346
350	290	127	290	380	605	604	750	40	35	457	328	393

PN 160										(kg)		
DN	LF	LW	LB	H1	H2	A	B	Df	dw	DFS	WV	BW
80	180	64	180	195	315	402	750	25	25	94	71	84
100	190	64	190	215	350	402	750	25	25	140	105	124
150	210	76	210	250	400	420	750	30	30	210	135	186
200	230	89	230	295	475	543	750	30	30	252	188	220
250	250	114	250	335	510	543	750	35	35	327	233	280
300	270	114	270	370	600	604	750	35	35	470	336	403